

GRINNELL G-FIRE Figure 71 Flange Adapters 2 to 12 Inch (DN50 to DN300)

General Description

The GRINNELL G-FIRE Figure 71 Flange Adapters allow a direct transition from flanged components to GRINNELL G-FIRE components. Flange bolt patterns conform to ANSI Class 125 and 150 standards as well as PN10 and PN16 as indicated.

NOTICE

The GRINNELL G-FIRE Figure 71 Flange Adapters described herein must be installed and maintained in compliance with this document and with the applicable standards of the National Fire Protection Association, in addition to the standards of any authorities having jurisdiction. Failure to do so may result in serious personal injury or impair the performance of these devices.

Never remove any piping component nor correct or modify any piping deficiencies without first de-pressurizing and draining the system. Failure to do so may result in serious personal injury, property damage, and/or impaired device performance.

It is the designer's responsibility to select products suitable for the intended service and to ensure that pressure ratings and performance data are not exceeded. Material and gasket selection should be verified to be compatible for the specific application. Always read and understand the installation instructions.

The owner is responsible for maintaining their fire protection system and devices in proper operating condition. Contact the installing contractor or product manufacturer with any questions.

Technical Data

Approvals
UL and ULC Listed
FM Approved
VdS Approved
LPCB (Cert. Nos. 669a and 673a)

Refer to Table A for details.

Sizes
2 to 12 Inch (DN50 to DN300)

Housing
Ductile iron conforming to ASTM A536, Grade 65-45-12

Finish

- Orange, non-lead paint
- Red, non-lead paint
- Hot-dipped, Galvanized conforming to ASTM A153

Gaskets

- Grade "E" EPDM, Green color code, -30°F to 230°F (-34°C to 110°C)

For dry and freezer systems, lubrication is required. Refer to Installation Manual IH-1000FP for details.

For proper gasket selection, refer to Technical Data Sheet TFP1895.

Care and Maintenance

The GRINNELL G-FIRE Figure 71 Flange Adapters must be maintained in accordance with this section.

Before closing a fire protection system main control valve for maintenance work on the fire protection system that it controls, obtain permission to shut down the affected fire protection system from the proper authorities and notify all personnel who may be affected by this decision.

After placing a fire protection system in service, notify the proper authorities and advise those responsible for monitoring proprietary and/or central station alarms.

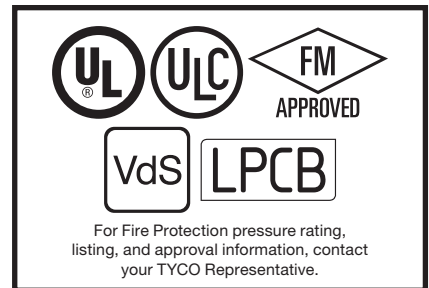

The owner is responsible for the inspection, testing, and maintenance of their fire protection system and devices in compliance with this document, as well as with the applicable standards of the National Fire Protection Association (e.g., NFPA 25), in addition to the standards of any authority having jurisdiction. Contact the installing contractor or product manufacturer with any questions. Any impairments must be immediately corrected.

Automatic sprinkler systems are recommended to be inspected, tested, and maintained by a qualified Inspection Service in accordance with local requirements and/or national codes.

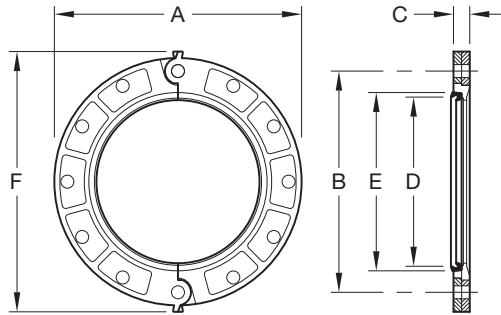

Pipe Size		Max ^b Press. psi (bar)	Max End Load ^b Lbs. (kN)	Nominal Dimensions Inches (mm)						Recommended Flange Mating Bolts ^c			Approx. Wt. Lbs. (kg)
Nominal ANSI Inch (DN)	O.D. Inches (mm)			A	B	C	D ^a	E ^a	F	Size Dia. x Lg. Inches	Qty.	Bolt Torque Range Lbs.-ft. (Nm)	
2 (DN50)	2.375 (60,3)	250 (17,2)	1108 (4,93)	6.38 (162,1)	4.75 (120,7)	0.75 (19,1)	2.38 (60,5)	3.41 (86,6)	7.25 (184,2)	5/8 x 3	4	110-140 (149-190)	3.0 (1,4)
2-1/2 (DN65)	2.875 (73,0)	250 (17,2)	1623 (7,22)	7.00 (178,0)	5.50 (140,0)	0.88 (22,0)	2.88 (73,0)	3.91 (99,0)	7.88 (200,0)	5/8 x 3	4	110-140 (149-190)	5.0 (2,3)
3 (DN80)	3.500 (88,9)	250 (17,2)	2405 (10,70)	7.50 (190,5)	6.00 (152,4)	0.94 (23,9)	3.50 (88,9)	4.53 (115,1)	9.88 (251,0)	5/8 x 3	4	110-140 (149-190)	5.6 (2,5)
4 (DN100)	4.500 (114,3)	250 (17,2)	3976 (17,69)	9.00 (228,6)	7.50 (190,5)	0.94 (23,9)	4.50 (114,3)	5.53 (140,5)	9.90 (251,5)	5/8 x 3	8	110-140 (149-190)	7.0 (3,2)
5 (DN125)	5.563 (141,3)	250 (17,2)	6076 (27,03)	10.00 (254,0)	8.50 (215,9)	1.00 (25,4)	5.56 (141,2)	6.72 (170,7)	11.38 (289,1)	3/4 x 3-1/2	8	220-250 (298-339)	9.2 (4,2)
6 (DN150)	6.625 (168,3)	250 (17,2)	8618 (38,33)	11.00 (279,4)	9.50 (241,3)	1.00 (25,4)	6.62 (168,1)	7.78 (197,6)	11.88 (301,8)	3/4 x 3-1/2	8	220-250 (298-339)	10.0 (4,5)
8 (DN200)	8.625 (219,1)	250 (17,2)	14607 (64,97)	13.50 (342,9)	11.75 (298,5)	1.13 (28,7)	8.62 (218,9)	9.94 (252,5)	14.38 (365,3)	3/4 x 3-1/2	8	220-250 (298-339)	16.6 (7,5)
10 (DN250)	10.750 (273,0)	250 (17,2)	22,691 (100,93)	16.00 (406,4)	14.25 (362,0)	1.19 (30,2)	10.75 (273,1)	12.31 (312,7)	16.88 (428,8)	7/8 x 4	12	320-400 (434-542)	21.8 (9,9)
12 (DN300)	12.750 (323,9)	250 (17,2)	31919 (141,98)	19.00 (482,6)	17.00 (431,8)	1.25 (31,8)	12.75 (323,9)	14.31 (363,5)	20.00 (508,0)	7/8 x 4	12	320-400 (434-542)	24.2 (11,0)

- a. Dimensions D and E represent minimum and maximum sealing surfaces.
- b. Maximum pressure and end load are total from all loads based on standard weight steel pipe. Pressure ratings and end loads may differ on other pipe materials and/or wall thickness. Contact your TYCO Representative for details.
- c. Mating Bolts and Nuts are not supplied. Flange Mating Bolts must be at least SAE J429 Grade 5 or stronger. Bolt lengths are standard; it is the responsibility of the purchaser to verify correct length for the intended application.

FIGURE 1
FIGURE 71 FLANGE ADAPTER
FOR USE WITH ANSI CLASS 125 AND 150 FLANGES

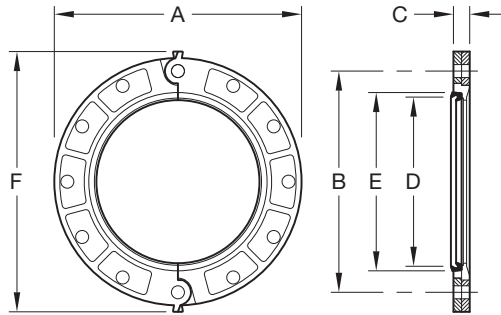

Pipe Size		Flange Bolt Pattern	Max ^c Press. psi (bar)	Max End Load ^c Lbs. (kN)	Nominal Dimensions Inches (mm)						Recommended Flange Mating Bolts ^d			Approx. Wt. Lbs. (kg)
Nominal ANSI Inch (DN)	O.D. (mm)				A	B	C	D ^a	E ^a	F	Size Dia. x Lg.	Qty.	Bolt Torque Range Nm	
2 (DN50)	60.3	PN10/ PN16	250 (17,2)	1108 (4,93)	6.38 (162,1)	4.92 (125,0)	0.75 (19,1)	2.38 (60,5)	3.41 (86,6)	7.25 (184,2)	M16 x 76	4	149-190	3.0 (1,4)
- (DN65)	76,1	PN10/ PN16	250 (17,2)	1767 (7,86)	7.28 (184,9)	5.71 (145,0)	0.88 (22,4)	3.00 (76,1)	4.03 (102,4)	8.09 (205,5)	M16 x 76	4	149-190	5.0 (2,3)
3 ^b (DN80)	88.9	PN10	250 (17,2)	2405 (10,70)	7.88 (200,2)	6.30 (160,0)	0.94 (23,9)	3.50 (88,9)	4.53 (115,1)	8.75 (222,3)	M16 x 76	4	149-190	5.6 (2,5)
3 (DN80)	88.9	PN16	250 (17,2)	2405 (10,70)	7.88 (200,2)	6.30 (160,0)	0.94 (23,9)	3.50 (88,9)	4.53 (115,1)	8.75 (222,3)	M16 x 76	8	149-190	5.6 (2,5)
4 (DN100)	114.3	PN10/ PN16	250 (17,2)	3976 (17,69)	9.00 (228,6)	7.09 (180,1)	0.94 (23,9)	4.50 (114,3)	5.53 (140,5)	9.90 (251,5)	M16 x 76	8	149-190	7.0 (3,2)
- (DN125)	139.7	PN10/ PN16	250 (17,2)	5940 (26,42)	9.84 (249,9)	8.27 (210,1)	1.00 (25,4)	5.50 (139,7)	6.53 (165,9)	10.69 (271,5)	M16 x 89	8	149-190	9.2 (4,2)
- (DN150)	165.1	PN10/ PN16	250 (17,2)	8296 (36,90)	11.25 (285,8)	9.45 (240,0)	1.00 (25,4)	6.50 (165,1)	7.53 (191,3)	12.12 (307,8)	M20 x 89	8	298-339	10.0 (4,5)
6 (DN150)	168.3	PN10/ PN16	250 (17,2)	8618 (38,33)	11.00 (279,4)	9.49 (241,1)	1.00 (25,4)	6.62 (168,1)	7.78 (197,6)	11.88 (301,8)	M20 x 89	8	298-339	16.6 (7,5)
8 ^b (DN200)	219.1	PN10	250 (17,2)	14607 (64,97)	13.38 (339,9)	11.61 (294,9)	1.13 (28,7)	8.62 (218,9)	9.94 (252,5)	14.31 (363,5)	M20 x 89	8	298-339	21.8 (9,9)
8 (DN200)	219.1	PN16	250 (17,2)	14607 (64,97)	13.38 (339,9)	11.61 (294,9)	1.13 (28,7)	8.62 (218,9)	9.94 (252,5)	14.31 (363,5)	M20 x 89	12	298-339	21.8 (9,9)
10 ^b (DN250)	273.0	PN10	250 (17,2)	22691 (100,93)	15.56 (395,2)	13.78 (350,0)	1.19 (30,2)	10.75 (273,1)	12.31 (312,7)	16.50 (419,1)	M22 x 102	12	298-339	22.5 (10,2)
10 (DN250)	273.0	PN16	250 (17,2)	22691 (100,93)	16.00 (406,4)	13.98 (355,1)	1.19 (30,2)	10.75 (273,1)	12.31 (312,7)	16.88 (428,8)	M22 x 102	12	434-542	24.2 (11,0)
12 ^b (DN300)	323.9	PN10	250 (17,2)	31919 (141,98)	17.52 (445,0)	17.52 (445,0)	1.25 (31,8)	12.75 (323,9)	14.31 (363,9)	16.56 (420,6)	M20 x 102	12	298-339	27.5 (12,5)
12 (DN300)	323.9	PN16	250 (17,2)	31919 (141,98)	18.12 (460,2)	18.12 (460,2)	1.25 (31,8)	12.75 (323,9)	14.31 (363,9)	19.14 (486,2)	M22 x 102	12	434-542	28.0 (12,7)

- a. Dimensions D and E represent minimum and maximum sealing surfaces.
- b. For noted sizes, PN10 and PN16 dimensional values differ.
- c. Maximum pressure and end load are total from all loads based on standard weight steel pipe. Pressure ratings and end loads may differ on other pipe materials and/or wall thickness. Contact your TYCO Representative for details.
- d. Mating Bolts and Nuts are not supplied. Flange Mating Bolts must be at least SAE J429 Grade 5 or stronger. Bolt lengths are standard; it is the responsibility of the purchaser to verify correct length for the intended application.

FIGURE 2
FIGURE 71 FLANGE ADAPTER
FOR USE WITH PN10 AND PN16 FLANGES

Pipe Sizes Nominal ANSI Inches (O.D. mm)	Pipe Schedule ^c	Pressure Rating psi (bar)		
		UL	ULC	FM
2 (60,3); 2-1/2 (73,0); 3 (88,9); 4 (114,3); 5 (141,3); 6 (168,3); 8 (219,1) ^a	10	250 (17,24)	250 (17,24)	250 (17,24)
	40	250 (17,24)	250 (17,24)	250 (17,24)
10 (273,0) ^a	10	250 (17,24)	250 (17,24)	250 (17,24)
	40	250 (17,24)	250 (17,24)	250 (17,24)
12 (323,9) ^b	10	250 (17,24)	250 (17,24)	250 (17,24)
	40	250 (17,24)	250 (17,24)	250 (17,24)

Pipe O.D. mm	Pipe Specification ^c	Pressure Rating psi (bar)	
		UL	FM
76,1; 165,1	ISO 4200	250 (17,24)	250 (17,24)
	EN 10255 Heavy	250 (17,24)	250 (17,24)
	EN 10255 Medium	250 (17,24)	250 (17,24)
139,7	ISO 4200	250 (17,24)	250 (17,24)
	EN 10255 Heavy	-	250 (17,24)
	EN 10255 Medium	-	250 (17,24)

Pipe Sizes Nominal ANSI Inches (O.D. mm)	Pipe Specification ^d	Pressure Rating psi (bar)	
		LPCB	VdS
2 (60,3); – (76,1); 3 (88,9); 4 (114,3); – (165,1)	ISO 65 Medium	290 (20)	-
6 (168,3); 8 (219,1); 10 (273,0)	ISO 4200 Wall Thickness 5,4 mm	290 (20)	-
12 (323,9)	ISO 4200 Wall Thickness 5,4 mm	232 (16)	-
2 (60,3); – (76,1); 3 (88,9); 4 (114,3); – (139,7); 6 (168,3)	DIN 2448 or 2548	-	232 (16)

- a. For 8 and 10 inch sizes, minimum allowed pipe wall thickness is 0.188 inches
- b. For 12 Inch, Schedule 30 is minimum allowed pipe wall thickness by UL and ULC. 0.250 inch wall thickness is the minimum allowed by FM
- c. See Agency website for Listing/Approvals of other pipe specifications:
UL Website - see Online Certificate Directory, www.ul.com
FM Global Website - www.approvalguide.com
- d. See Agency website for Listing/Approvals of other pipe specifications:
LPCB Website - see Search Our Listings - Automatic Sprinklers, Water Spray and Deluge Systems, www.redbooklive.com
VdS Website - see certifications, www.vds.de

**TABLE A
LISTED/APPROVED PRESSURE RATINGS**

Limited Warranty

For warranty terms and conditions, visit www.tyco-fire.com

Ordering Procedure

GRINNELL Products are available globally through a network of distribution centers. Visit www.tyco-fire.com for the nearest distributor.

When placing an order, indicate the full product name. Specify the following:

- GRINNELL G-FIRE Figure 71 Flange Adapter;
- Quantity;
- Size: ANSI Inch size, DN, or pipe O.D.;
- Flange Bolt Pattern Designation: Class 125, 150 or PN10, PN16;
- Protective coating: non-lead orange paint, RAL red non-lead paint, or hot-dipped galvanized; and
- Type of gasket: Grade "E" EPDM

