

Resilient-Seated Gate Valves Outside Screw and Yoke

General Description

TYCO Resilient-Seated Gate Valves are used in Fire Protection Systems for on/off operation. End connection configurations including Flange x Flange, Flange x Groove, and Groove x Groove are available. The Flange x Flange body valves feature two plugged tapping bosses for quick and direct connection.

The ductile Iron body weighs approximately 50% less than conventional cast iron valves, which allows easier handling on site and reduced shipping costs.

The fully encapsulated EPDM ductile iron Wedge ensures bubble-tight sealing.

Valve components are either inherently corrosion-resistant or protected with fusion-bonded epoxy resin coating for a long, dependable service life and enhanced UV protection in exposed installations.

This valve is one of the lightest, most durable gate valves on the market today. Its design features and material selection criteria fulfill the need for a dependable, long life and easy to operate gate valve.

NOTICE

Never remove any piping component nor correct or modify any piping deficiencies without first de-pressurizing and draining the system. Failure to do so may result in serious personal injury, property damage, and/or impaired device performance.

It is the designer's responsibility to select products suitable for the intended service and to ensure that pressure ratings and performance data are not exceeded. Material and gasket selection should be verified for com-

patibility with the specific application. Always read and understand the installation instructions.

TYCO Gate Valves described herein must be installed and maintained in compliance with this document, in addition to the standards of any other authorities having jurisdiction. Failure to do so may result in serious personal injury or impair the performance of these devices.

The owner is responsible for maintaining their mechanical system and devices in proper operating condition. The installing contractor or device manufacturer should be contacted with any questions.

Technical Data

Sizes

2 in. (DN50), 2-1/2 in. (DN65), 3 in. (DN80),
4 in. (DN100), 6 in. (DN150), 8 in. (DN200),
10 in. (DN250), and 12 in. (DN300)

Approvals

UL Listed
FM Approved

Maximum Working Pressure

UL - 300 psi (20,87 bar)
FM - 232 psi (16 bar)

End Connections

Flange x Flange, Flange x Groove or
Groove x Groove
(Ref. Table A for size applicability)

Flanges

ASME B16.1/ASME B16.42
EN 1092-2/ISO 7005-2
Drilled to ANSI 125/150 or PN10/PN16 or
AS 2129 (Table E)

Materials of Construction

Ref. Figure 1

Tapping Bosses

Two factory-plugged NPT threaded tapping bosses in the Flange x Flange body valve are located on the up- and downstream sides of the wedge for connection to valve trim. Tapping boss NPT Inch sizes:

2 in. - 4 in. (DN50-DN100)..... 1/2
6 in. - 8 in. (DN150-DN200)..... 3/4
10 in. - 12 in. (DN250-DN300)..... 1

NOTE: The tapping bosses are only available in the Flange x Flange body valve.



IMPORTANT

Refer to Technical Data Sheet TFP2300 for warnings pertaining to regulatory and health information.

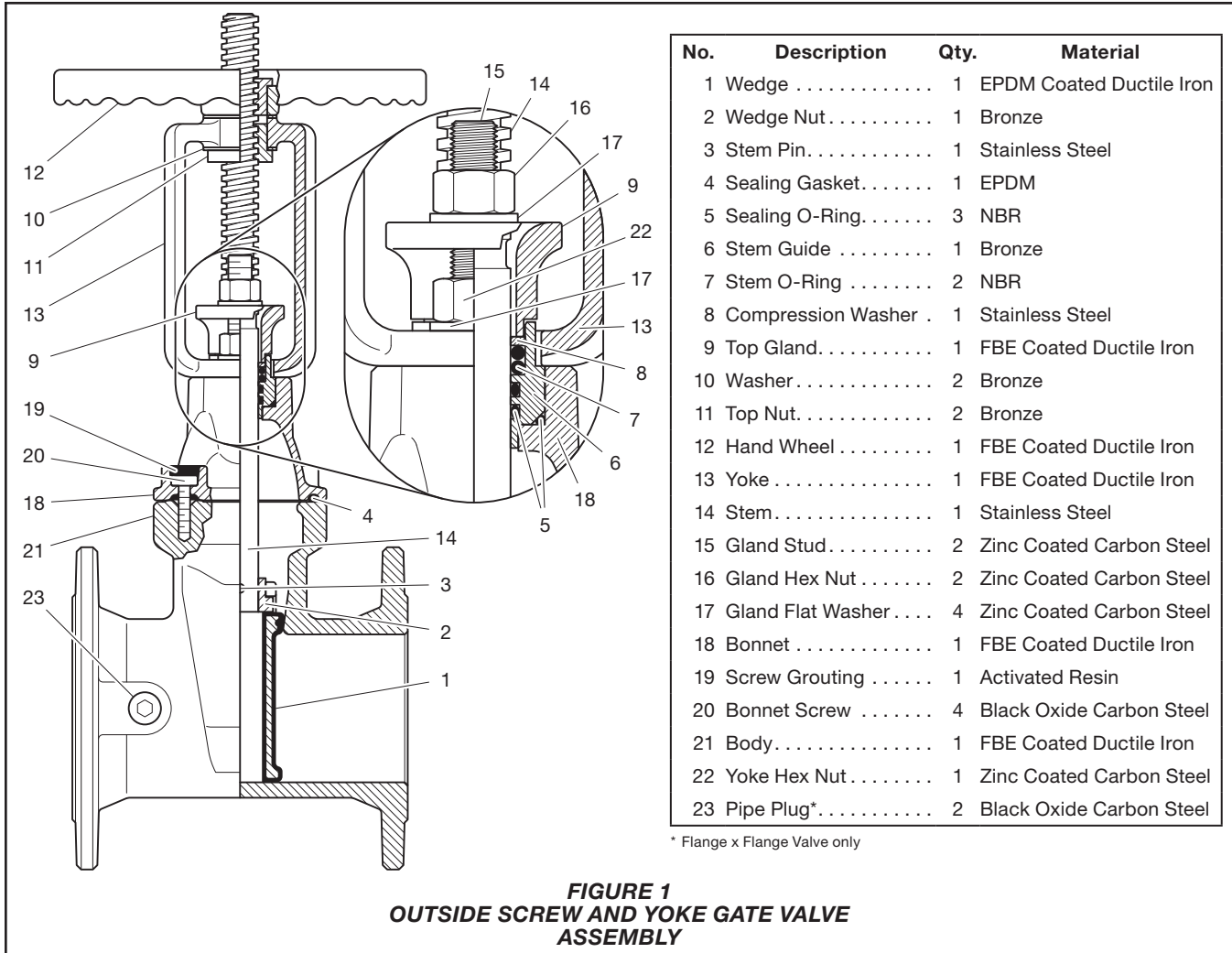

Installation

In piping systems, TYCO Resilient-Seated Gate Valves should be located where operation, inspection, and maintenance are readily accessible.

Care and Maintenance

The TYCO Resilient-Seated Gate Valves must be maintained and serviced in accordance with this section.

Before closing a fire protection system main control valve for maintenance work on the fire protection system that it controls, obtain permission to shut down the affected fire protection system from the proper authorities and notify all personnel who may be affected by this decision.

After placing a fire protection system in service, notify the proper authorities and advise those responsible for monitoring proprietary and/or central station alarms.

The owner is responsible for the inspection, testing, and maintenance of their fire protection system and devices in compliance with this document, as well as with the applicable standards of the NATIONAL FIRE PROTECTION ASSOCIATION (e.g., NFPA 25), in addition to the standards of any authority having jurisdiction. The installing contractor or product manufacturer should be contacted relative to any questions. Any impairments must be immediately corrected.

Automatic sprinkler systems are recommended to be inspected, tested, and maintained by a qualified Inspection Service in accordance with local requirements and/or national codes.

See Figure 1 for valve components referenced in this section.

Debris lodged in the sealing area of the Wedge (1) may cause the valve to close hard. Backing off the Handwheel (12) and closing it again, several times if necessary, can correct this problem.

The valve should never be forced to seat by applying a wrench or extension to the Handwheel (12), as it may distort the valve components or score the sealing surfaces. All replacement parts must be obtained from the manufacturer to assure proper operation of the valve.

At initial valve installation the Gland Hex Nuts (16) should be left only finger tight to allow the Gland (9) to remain in a relaxed state during normal valve operation. For applications where the valve is subject to vibration, a non-hardening thread sealant may be applied to the Gland Hex Nuts (16) to prevent self-loosening and subsequent disengagement of the Gland (9).

If leakage past the Sealing O-Rings (5) occurs, evenly tighten the Gland Hex Nuts (16) until the leakage ceases.

Nominal Valve Size	Nominal Pipe Size	Nominal Dimensions Inches (mm)			P Tapping Boss Size ^a ANSI Inch NPT	Nominal Handwheel Turns to Fully Operate (Open or Shut)	Approx. Weight F x F Lbs. (kg)	Approx. Weight F x G Lbs. (kg)	Approx. Weight G x G Lbs. (kg)
		L	CL1	CL2					
2 DN50	2.375 (60,3)	7.00 (178)	15.55 (395)	13.07 (332)	1/2	13	29.8 (13,5)	27.6 (12,5)	25.4 (11,5)
2-1/2 DN65	2.875 (73,0)	7.50 (190)	16.14 (410)	13.31 (338)		16	35.3 (16)	30.9 (14)	26.5 (12)
– DN65	3.000 (76,1)	7.50 (190)	16.14 (410)	13.31 (338)		16	–	30.9 (14)	26.5 (12)
3 DN80	3.500 (88,9)	8.00 (203)	18.9 (480)	14.96 (380)		20	41.9 (19)	36.4 (16,5)	30.9 (14)
4 DN100	4.500 (114,3)	9.00 (229)	22.56 (573)	17.72 (450)		20	57.3 (26)	50.7 (23)	44.1 (20)
– DN150	6.500 (165,1)	10.50 (267)	29.53 (750)	23.31 (592)	3/4	25	–	88.2 (40)	79.4 (36)
6 DN150	6.625 (168,3)	10.50 (267)	29.53 (750)	23.31 (592)		25	97.0 (44)	88.2 (40)	79.4 (36)
8 DN200	8.625 (219,1)	11.50 (292)	37.64 (956)	29.45 (748)		34	154.4 (70)	143.3 (65)	110.3 (50)
10 DN250	10.750 (273,1)	13.00 (330)	46.26 (1175)	34.96 (888)	1	42	264.6 (120)	242.6 (110)	220.5 (100)
12 DN300	12.750 (323,9)	14.00 (356)	51.89 (1318)	39.57 (1005)		50	330.8 (150)	297.7 (135)	275.6 (125)

Notes:
a. Flange x Flange Valve only

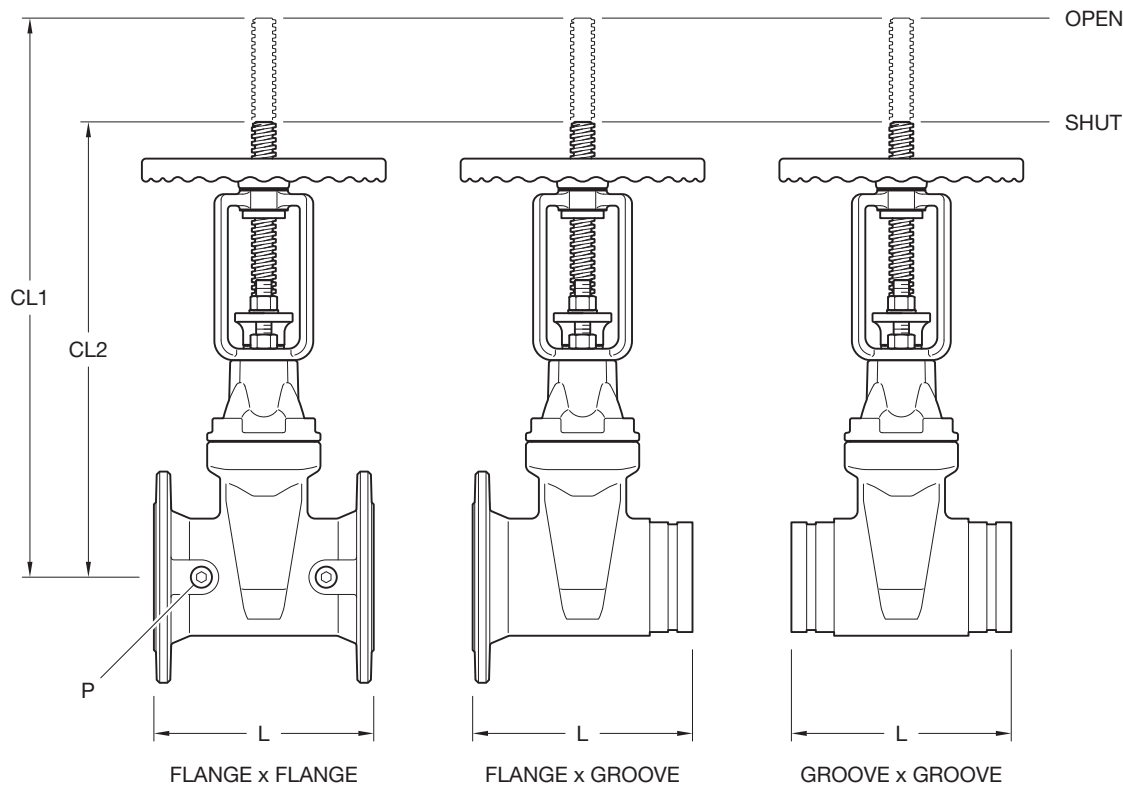

FIGURE 2
OUTSIDE SCREW AND YOKE GATE VALVE
NOMINAL DIMENSIONS

Nominal Valve Size	Nominal Dimensions in Inches (mm)								
	ANSI Class 150			ISO 7005-2 PN16			AS 2129 (Table E)		
	Dim. A	Dim. B	Qty. N	Dim. A	Dim. B	Qty. N	Dim. A	Dim. B	Qty. N
2 DN50	4.75 (120,5)	0.75 (19)	4	4.92 (125,0)	0.75 (19)	4	4.48 (114,0)	0.71 (18,0)	4
2-1/2 DN65	5.50 (139,5)	0.75 (19)	4	5.71 (145,0)	0.75 (19)	4	5.00 (127,0)	0.71 (18,0)	4
3 DN80	6.00 (152,5)	0.75 (19)	4	6.30 (160,0)	0.75 (19)	8	5.74 (146,0)	0.71 (18,0)	4
4 DN100	7.50 (190,5)	0.75 (19)	8	7.09 (180,0)	0.75 (19)	8	7.00 (178,0)	0.71 (18,0)	8
6 DN150	9.50 (241,5)	0.88 (22)	8	9.45 (240,0)	0.88 (23)	8	9.25 (235,0)	0.87 (22,0)	8
8 DN200	11.75 (298,5)	0.88 (22)	8	11.61 (295,0)	0.88 (23)	12	11.49 (292,0)	0.87 (22,0)	8
10 DN250	14.25 (362,0)	1.00 (25)	12	13.98 (355,0)	1.13 (28)	12	14.02 (356,0)	0.87 (22,0)	12
12 DN300	17.00 (432,0)	1.00 (25)	12	16.14 (410,0)	1.13 (28)	12	15.98 (406,0)	1.02 (26,0)	12

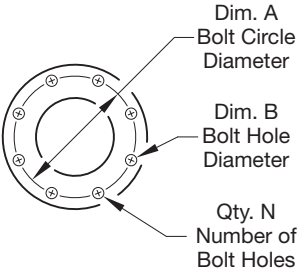
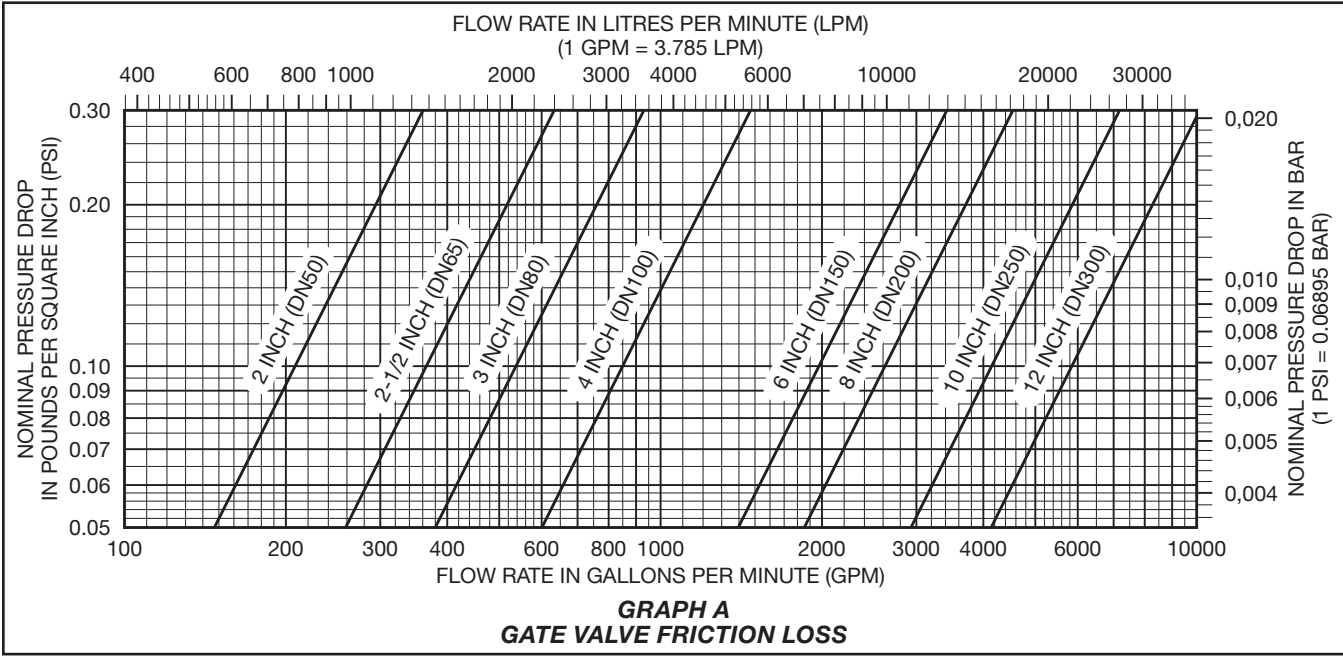

FIGURE 3
GATE VALVE FLANGE
NOMINAL DIMENSIONS



Nominal Valve Size	Nominal Pipe Size	Part Number					
		Flange x Flange ANSI Class 150	Flange x Flange ISO 7005-2 PN16	Flange x Groove ANSI Class 150	Flange x Groove ISO 7005-2 PN16	Flange x Flange AS 2129 (Table E)	Groove x Groove
2 DN50	2.375 (60,3)	TMRX-0500003TB	TMRX-0500001TB	TMRT-0500603	TMRT-0500601	TMRX-0500005TB	TMRG-0500604
2-1/2 DN65	2.875 (73,0)	TMRX-0650003TB	TMRX-0650001TB	TMRT-0650733	TMRT-0650731	TMRX-0650005TB	TMRG-0650734
– DN65	3.000 (76,1)	–	–	TMRT-0650763	TMRT-0650761	–	TMRG-0650764
3 DN80	3.500 (88,9)	TMRX-0800003TB	TMRX-0800001TB	TMRT-0800893	TMRT-0800891	TMRX-0800005TB	TMRG-0800894
4 DN100	4.500 (114,3)	TMRX-1000003TB	TMRX-1000001TB	TMRT-1001143	TMRT-1001141	TMRX-1000005TB	TMRG-1001144
– DN150	6.500 (165,1)	–	–	TMRT-1501653	TMRT-1501651	–	TMRG-1501654
6 DN150	6.625 (168,3)	TMRX-1500003TB	TMRX-1500001TB	TMRT-1501683	TMRT-1501681	TMRX-1500005TB	TMRG-1501684
8 DN200	8.625 (219,1)	TMRX-2000003TB	TMRX-2000001TB	TMRT-2002193	TMRT-2002191	TMRX-2000005TB	TMRG-2002194
10 DN250	10.750 (273,1)	TMRX-2500003TB	TMRX-2500001TB	TMRT-2502733	TMRT-2502731	TMRX-2500005TB	TMRG-2502734
12 DN300	12.750 (323,9)	TMRX-3000003TB	TMRX-3000001TB	TMRT-3003243	TMRT-3003241	TMRX-3000005TB	TMRG-3003244

TABLE A
OUTSIDE SCREW AND YOKE GATE VALVE
PART NUMBERS

Limited Warranty

For warranty terms and conditions, visit www.tyco-fire.com.

Ordering Procedure

Contact your local distributor for availability. When placing an order, indicate the full product name and Part Number (P/N). Refer to Table A for a complete list of part numbers.

