

## Model BFV-N Butterfly Valve Lug Style

### General Description

The TYCO Model BFV-N Lug Style Butterfly Valves (Ref. Figure 1) are indicating type valves designed for use in fire protection systems where a visual indication is required as to whether the valve is open or closed. They are used, for example, as system, sectional, and pump water control valves. They are suitable for installation between ANSI Class 125 or 150 flanges without the need for flange gaskets.

For applications requiring supervision of the open position of the valve, the Gear Operators for the Model BFV-N Butterfly Valves are provided with two sets of factory installed internal switches each having SPDT contacts. The supervisory switches transfer their electrical contacts when there is movement from the valve's normal open position during the first two revolutions of the handwheel.

#### **NOTICE**

*The TYCO Model BFV-N Lug Style Butterfly Valves described herein must be installed and maintained in compliance with this document, as well as with the applicable standards of the National Fire Protection Association, in addition to the standards of any other authorities having jurisdiction. Failure to do so may impair the performance of these devices.*

*The owner is responsible for maintaining their fire protection system and devices in proper operating condition. Contact the installing contractor or product manufacturer with any questions.*

### Technical Data

**Model**  
BFV-N

**Sizes: ANSI Inches (DN)**  
2 (DN50), 2-1/2 (DN65), 3 (DN80),  
4 (DN100), 5 (DN125), 6 (DN150),  
8 (DN200), 10 (DN250), 12 (DN300)

**Approvals**  
UL and C-UL Listed  
FM Approved  
California State Fire Marshall under  
Listing No. 7770-1670:101

**Maximum Working Pressure**  
250 psi (17,2 bar). For dead end service the  
maximum pressure is 200 psi (13,8 bar)

#### **Materials of Construction:**

**Body**  
Ductile iron conforming to ASTM A536

**Disc**  
Ductile iron conforming to ASTM A395,  
Nickel Plated

**Seat Material**  
Grade EPDM "E" rubber conforming to  
ASTM D2000

**Upper Stem**  
Type 416 Stainless Steel conforming to  
ASTM 582

**Operator**  
Gear operator with iron housing



#### **Friction Loss**

The approximate friction loss, based on the Hazen Williams formula and expressed in equivalent length of pipe with C=120, is as follows. Unless otherwise indicated, the data is based on friction loss information collected at a typical flow rate of 15 feet per second.

- 4.4 feet of 2 inch Sch. 40 pipe for the 2 inch valve.
- 6.2 feet of 2-1/2 inch Sch. 40 pipe for the 2-1/2 inch valve.
- 7.6 feet of 3 inch Sch. 40 pipe for the 3 inch valve.
- 9.2 feet of 4 inch Sch. 40 pipe for the 4 inch valve.
- 9.0 feet\* of 5 inch Sch. 40 pipe for the 5 inch valve.
- 8.2 feet of 6 inch Sch. 40 pipe for the 6 inch valve.
- 12.7 feet\* of 8 inch Sch. 30 pipe for the 8 inch valve.
- 20.1 feet\* of 10 inch Sch. 30 pipe for the 10 inch valve.
- 22.3 feet\* of 12 inch Sch. 30 pipe for the 12 inch valve.

\*NFPA 13

Nominal Valve Sizes Inches (DN)	Nominal Installation Dimensions Inches (mm)										Weight Lbs. (kg)
	A	B	C	D	E	F	G	H	J	K	
2 (50)	2.53 (64,0)	1.68 (43,0)	12.62 (320,5)	2.88 (73,0)	6.48 (164,6)	6.00 (152,4)	5.80 (147,3)	2.12 (53,8)	1.38 (35,1)	5/8-11	21 (10,0)
2-1/2 (65)	2.90 (74,0)	1.81 (46,0)	13.51 (343,1)	3.25 (83,0)	6.98 (177,3)	6.00 (152,4)	5.80 (147,3)	2.12 (53,8)	2.00 (50,8)	5/8-11	24 (11,0)
3 (80)	3.17 (81,0)	1.81 (46,0)	13.88 (352,6)	3.38 (86,0)	7.22 (183,4)	6.00 (152,4)	5.80 (147,3)	2.12 (53,8)	2.55 (64,8)	5/8-11	24 (11,0)
4 (100)	4.17 (106,0)	2.06 (52,0)	15.24 (387,0)	4.00 (101,6)	7.98 (202,7)	6.00 (152,4)	5.80 (147,3)	2.12 (53,8)	2.58 (65,5)	5/8-11	27 (12,0)
5 (125)	5.17 (131,0)	2.19 (56,0)	16.49 (418,8)	4.75 (121,0)	8.48 (215,4)	6.00 (152,4)	7.80 (198,1)	2.12 (53,8)	4.64 (117,9)	3/4-10	31 (14,1)
6 (150)	6.17 (157,0)	2.19 (56,0)	17.65 (448,3)	5.25 (133,0)	9.10 (231,1)	6.00 (152,4)	7.80 (198,1)	2.12 (53,8)	5.75 (146,1)	3/4-10	34 (15,0)
8 (200)	8.17 (208,0)	2.38 (60,0)	20.11 (510,8)	6.50 (165,0)	10.35 (262,9)	10.00 (254,0)	7.90 (200,7)	2.12 (53,8)	7.77 (197,4)	3/4-10	49 (22,0)
10 (250)	10.17 (258,0)	2.68 (69,0)	23.35 (593,1)	8.00 (203,0)	12.27 (311,7)	11.80 (300,0)	9.50 (241,3)	3.03 (77,0)	9.77 (248,2)	7/8-9	78 (35,0)
12 (300)	12.17 (309,0)	3.00 (76,0)	26.10 (663,0)	9.25 (235,0)	13.77 (349,8)	11.80 (300,0)	9.50 (241,3)	3.03 (77,0)	11.75 (298,5)	7/8-9	103 (47,0)

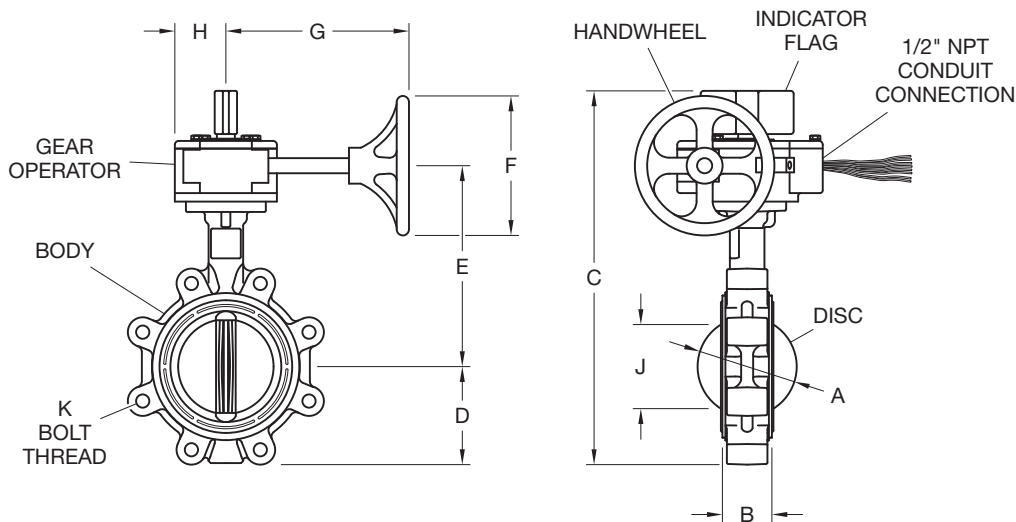

**FIGURE 1**  
**MODEL BFV-N LUG STYLE BUTTERFLY VALVE**  
**NOMINAL DIMENSIONS**

## Installation

The TYCO Model BFV-N Lug Style Butterfly Valves may be installed with flow in either direction and can be positioned either horizontally or vertically. They are designed for installation between the faces of ANSI Class 125 and 150 flanges. The Series BFV-N are self-sealing between mating flanges; therefore, they do not require the use of additional gaskets.

The Model BFV-N may be installed with any pressure class or schedule of pipe or tubing no greater than schedule 40 that is listed or approved for fire protection service and installed in accordance with the manufacturer's instructions.

Lug bodies have bolt hole locations that are the same as mating flanges. Refer to Figure 1 for bolt thread. Bolts and studs must meet the minimum strength requirements of ASTM A307 (Grade B), and the nuts must meet the minimum strength requirements of ASTM A563 (Grade A).

Prior to installation, close the valve. Spread the flanges apart to allow the valve to slip easily between the flanges. Make sure the pipe flange faces are clean of any foreign material such as scale, metal shavings, or welding slag. Insert the valve between the flanges (without flange gaskets). Do not apply lubricant to the seat faces as this may

Nominal Flange Size ANSI Inches (DN)	Recommended Minimum Torque Ft.-Lbs (Nm)
2 - 4 (50 - 100)	20 - 30 (27,1 - 40,7)
5 - 8 (125 - 200)	33 - 50 (44,7 - 67,8)
10 (250)	53 - 75 (71,8 - 101,7)
12 (300)	80 - 110 (108,4 - 149,1)
<b>TABLE A</b> <b>RECOMMENDED TORQUES</b>	

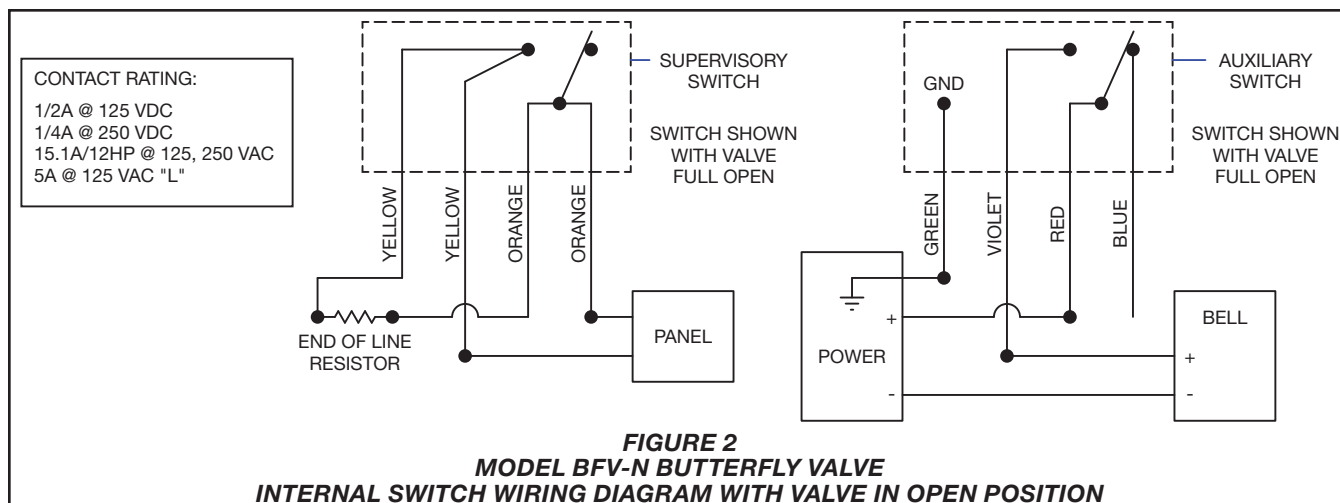

damage the seat material. Be sure to center the valve and do not damage the liner. Relax the separation of the flanges, install, and hand-tighten all flange bolts. Slowly open the valve, checking for free movement of the disc. If valve opens freely, leave the valve in the open position, and using a cross-draw sequence, tighten all flange bolts until the valve is metal-to-metal with both mating flanges. Recommended tightening torques are listed in Table A. Be certain to keep flange faces as parallel as possible during and after tightening bolts or studs. After final tightening, again check the valve for full opening and closing.

As applicable, refer to Figure 2 for the internal switch wiring diagram.

Conduit and electrical connections are to be made in accordance with the authority having jurisdiction and/or the National Electrical Code. With reference to Figure 2, the "supervisory switch" is intended for connection to the supervisory circuit of a fire alarm control panel in accordance with NFPA 72. The "auxiliary switch" is intended for the unsupervised connection to auxiliary equipment in accordance with NFPA 70, National Electric Code.

**NOTE:** For outdoor applications with internal supervisory switches, it is recommended that wiring connections be made at a temperature above 15°F (-9°C), in order to insure sufficient flexibility of the wire lead insulation.

#### Stop Adjustment Procedure

The gear operator's OPEN and SHUT position have been factory set. The following procedure should be used if slight adjustments are needed. Refer to Figure 3.

**Step 1.** Turn the Handwheel until the valve is fully closed.

**Step 2.** Remove the two Lock Screws (A) from the gear operator body.

**Step 3.** Turn the Shut Stop Screw (B) clockwise until snug.

**Step 4.** Turn the Handwheel until the valve is fully open.

**Step 5.** Turn the Open Stop Screw (C) clockwise until snug.

**Step 6.** Close the valve by turning the Handwheel until the valve is fully in the closed position. Ensure the disc has returned to the fully closed position and the disc is centered in the seat area. Readjust the Shut Stop Screw if necessary.

**Step 7.** Replace the two Lock Screws (A) into the gear operator body, locking the stops into position.

## Care and Maintenance

The TYCO Model BFV-N Lug Style Butterfly Valves must be maintained and serviced in accordance with this section.

Before closing a fire protection system control valve for maintenance or inspection work on either the valve or fire protection system which it controls, permission to shut down the affected fire protection systems must be obtained from the proper authorities and all personnel who may be affected by this decision must be notified.

The owner is responsible for the inspection, testing, and maintenance of their fire protection system and devices in accordance with the applicable standards of the National Fire Protection

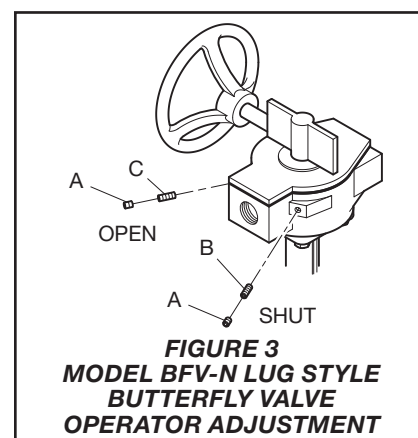

Association (e.g., NFPA 25), in addition to the standards of any authority having jurisdiction. Contact the installing contractor or product manufacturer with any questions. Any impairment must be immediately corrected.

It is recommended that automatic sprinkler systems be inspected, tested, and maintained by a qualified inspection service.

## **Limited Warranty**

For warranty terms and conditions, visit [www.tyco-fire.com](http://www.tyco-fire.com).

## **Ordering Procedure**

### **Lug Style Butterfly Valves:**

Specify: (specify inch size) Model BFV-N Lug Style Butterfly Valve with internal supervisory switches, P/N (specify)

<b>Valve Size</b>	<b>Valve Part Number</b>
2 .....	59-802-1-020N
2-1/2 .....	59-802-1-025N
3 .....	59-802-1-030N
4 .....	59-802-1-040N
5 .....	59-802-1-050N
6 .....	59-802-1-060N
8 .....	59-802-1-080N
10 .....	59-802-1-100N
12 .....	59-802-1-120N