



## Grinnell Mechanical Products Installation / Assembly Instructions, Model CB800 Circuit Balancing Valve

### General Description

GRINNELL CB800 Circuit Balancing Valves are designed for installation in hot water heating and chilled water air conditioning systems and serve to achieve a hydronic balance between the various circuits of the system.

These installation instructions are designed for the Grooved, Flanged, Threaded, and Soldered type Circuit Balancing Valves.

#### General Instructions

Always read and understand the instructions. Never remove any piping component without verifying that the system is depressurized and drained.

It is the designer's responsibility to select products suitable for the intended service and to ensure that pressure ratings and performance data are not exceeded.

It is recommended that the valve be installed in the return line.

Install the valve with the flow in the same direction as the arrow cast in the body.

Valve must be installed with a minimum of 3D (3 x nominal pipe diameter) of straight pipe in the upstream side.

Valve may be installed in the vertical or horizontal position, with the hand-wheel up, down or on the side.

#### Presetting

The required preset value can be obtained by referencing the flow chart for the appropriate size of valve. (See reference documents on [www.grinnell.com](http://www.grinnell.com)) Following the steps below, adjust the basic and fine adjustment scale on the handwheel to match the selected presetting.

**Step 1.** The preset value of the valve is adjusted with the handwheel (Ref. Figure 1 or 2).

**Step 2.** Turn the handwheel so that the arrow on the sliding indicator matches the basic adjustment value. One complete turn of the handwheel adjusts the indicator one full position.

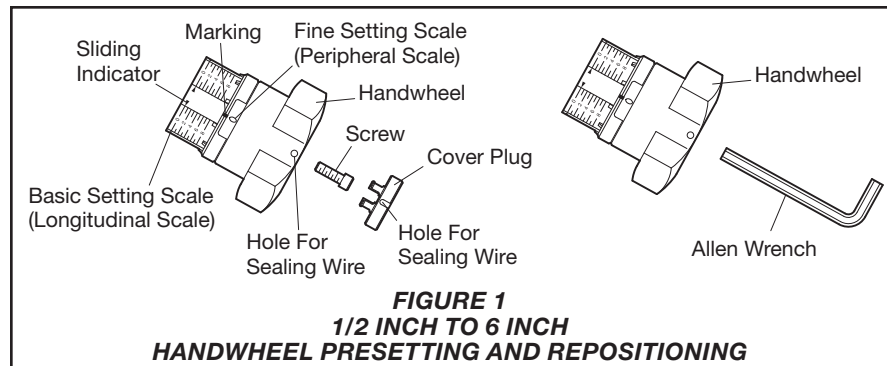

**FIGURE 1**  
**1/2 INCH TO 6 INCH**  
**HANDWHEEL PRESETTING AND REPOSITIONING**

The fine setting is displayed in the scale under the handwheel and indicates 1/10th of a turn of the handwheel.

**Step 3.** With the valve open to the preset value, use a small screwdriver and gently pry the cover plug out of the hand-wheel. Using a 3 mm Allen key for the 1/2 to 2 inch, 4 mm Allen key for the 2-1/2 to 6 inch, or a 10 mm screwdriver for the 8 to 12 inch, insert the tool into the screw (Ref. Figure 1 or 2) and turn clockwise until tight. This will lock the hand-wheel so that the valve can not be opened beyond the preset value. The hand-wheel may still be turned to the closed position. Replace the cover plug.

#### Repositioning the Handwheel

Depending on the position of the valve in the system, it may be desirable to move the 1/2 inch to 6 inch handwheel and adjustment scales to make it easier to read.

**Step 1.** Ensure the valve is closed and the adjustment scale is set at 0.

**Step 2.** Use a small screwdriver and gently pry the cover plug out of the hand-wheel.

**Step 3.** Use a 12 mm socket for the 1/2 inch to 2 inch handwheel and 6mm Allen key for the 2-1/2 inch to 6 inch handwheel to remove the Allen screw (Ref. Figure 1).

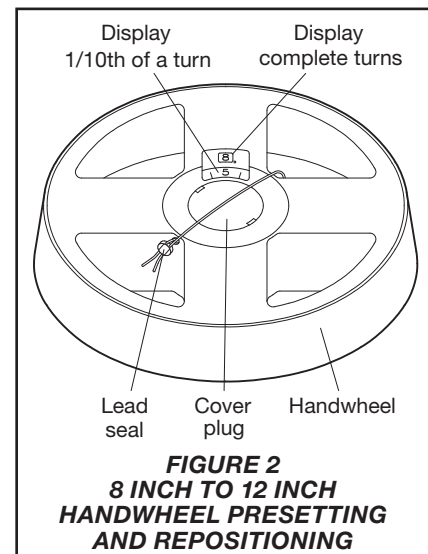

**FIGURE 2**  
**8 INCH TO 12 INCH**  
**HANDWHEEL PRESETTING AND REPOSITIONING**

**Step 4.** Gently pull the handwheel up and remove it from the valve spindle.

**Step 5.** Reposition the handwheel so that the adjustment scale is visible and slide the handwheel down on the spindle.

**Step 6.** Replace the screw and tighten.

**Step 7.** Replace the cover plug.

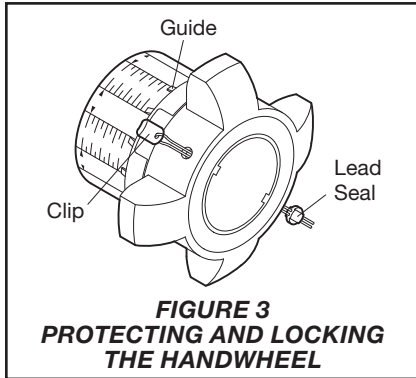

## Reference Documents

For more details, refer to the Instruction Handbook IH-4500 and Technical Data Sheet G450.

**10**  
YEAR  
LIMITED  
WARRANTY

For warranty terms and conditions, visit [www.grinnell.com](http://www.grinnell.com)

### Protecting the Setting

A sealing wire may be threaded through the hole in the handwheel (Ref. Figure 2 or 3) and the lead seal to be fixed to prevent tampering of the setting.

### Locking the Handwheel

#### Locking 1/2 Inch to 6 Inch Handwheel

The hand wheel can be locked in any position. Slide the enclosed clip into the cut-out in the hand wheel between the guides (Ref. Figure 3), making sure it locates into the sliding indicator. Attach the lead seal wire through the hole in the clip then through the hole in the side of the hand wheel. Ensure the sealing wire is fitted tightly, then crimp the seal.

#### Locking 8 Inch to 14 Inch Handwheel

The handwheel can be locked in any position (1/10th of a turn) by removing the existing cover plug and replacing it with a special one. The sealing wire is fitted through the hole in the handwheel and a Lead Seal is fitted (Ref. Figure 2).

### NOTICE

*For presetting and fine adjustment of the flow volume, use the Grinnell Model MC2 flow computing hand held Differential Measuring Computer.*